

Delivering power, **when you need it.**

CONTROL SYSTEM ARCHITECTURE

# ACVF<sup>™</sup> > system

Next-generation secure DC power for the utility and industry sectors.

 <p>Dependable, critical power when you need it.</p>	 <p>Simple maintenance.</p>	 <p>Utility and Grid installations.</p>	 <p>Control Thyristor &amp; Switch Mode Rectifiers providing expandable and scalable power.</p>	 <p>Wide range of system sizes as standard.</p>	 <p>Optitherm<sup>™</sup> convection cooled.</p>	
 <p>Recycling Options.</p>	 <p>Single or Three phase input.</p>	 <p>Intuitive touchscreen multi-menu display.</p>			 <p>Driving lower emissions.</p>	 <p>Ready for standby power, emergency lighting or as a power supply.</p>
 <p>Cost-effective lifetime solutions.</p>	<p>Compliance.</p> <p><b>NGTS &amp; ENATS</b></p>				 <p><b>Bespoke Variations</b> Including chassis only, dual charger schemes, self-contained units with an integrated battery compartment and units including power distribution panels.</p>	
<p>Output ranges</p> <p><b>12 &gt; 154VDC</b></p>	<p>Upto</p> <p><b>16</b></p> <p>Rectifiers per unit</p>	 <p>Various battery technologies capability.</p>	<p><b>5</b></p> <p><b>YEAR WARRANTY</b></p> <p>Standard throughout our product range.</p>			

The images in this document are for illustration purposes only and may not accurately represent the product.

## ACVF™ SYSTEM OVERVIEW

# At PE Systems, we are committed to simplifying and standardising our Battery Charger range, and our ACVF™ (Advanced Constant Voltage Float) Platform embodies this philosophy.

This innovative platform serves as a unifying foundation for all our current and future systems, including single-phase, three-phase and switched-mode modules.

Our primary goal is to modernise our thyristor products, bringing them in line with the advanced features of today's state-of-the-art switch mode systems, such as those offered by our premier partner Enedo. We harness the power of the latest technology and surface mount components to achieve this, a significant departure from our original controller designs that originated in the 1980s.

The ACVF™ architecture helps us streamline manufacturing while reducing interconnect wiring by employing patch cables between boards. This saves time and minimises costs and the potential for errors.

Furthermore, for ease of identification in production, and servicing, all ACVF™ boards designed by PE Systems are distinctively coloured in blue.

### WHAT DOES THE ACVF™ REPLACE?

The ACVF™ platform represents a substantial leap forward, replacing numerous original system components. These include the control board, battery temperature compensation board, gate drive board, auxiliary transformer, rectifier assembly, BM1 battery alarm monitor, alarm/function LEDs, analogue meters, snubber capacitor and resistor, alarm boards, relays, push buttons, and reducing interconnection wiring.

In their place, the ACVF™ introduces a streamlined set of components, including a touchscreen/system controller, rectifier assembly, a power supply (DC/DC), and patch cables.



For all our QHES Accreditations, please visit the website.

Delivering power, **when you need it.**



### THE TOUCH SCREEN AND INTERFACE CARD

The ACVF™ platform features a cutting-edge touchscreen and interface card with the following key attributes:

- 7" LCD touch screen displays
- Operating on the Android system
- Provides real-time system status
- Displays configurable system data
- Maintains detailed history logs
- Equipped with a tricolour system status LED
- Features audio alarm alerts
- Includes a clock function
- Utilises motion sensor to control LCD backlight
- Offers two configurable inputs/outputs
- All control and maintenance functions are accessible via the touch screen
- Connectivity options include Ethernet and USB
- Supports system configuration (view and change)
- Advanced user access control (User/Service/Expert)

### THE SINGLE-PHASE RECTIFIER

Each system can accommodate up to 16 single-phase rectifiers, though typically only one is required. These rectifiers offer versatile voltage support ranging from 24v to 110v without the need for hardware changes. With an onboard rectifier capacity of 1 – 15A, these units cover the power requirements of 90% of systems.

Each rectifier comes integrated with an auxiliary transformer, ensuring autonomous operation, and features a compact design for space efficiency. Additionally, these rectifiers offer a configurable input, two CANBUS ports, and status indication LEDs.

### SYSTEM CONTROLLER

Each system includes one controller, with variations available for different voltage ratings. The system controller boasts an array of functions and features, including:

- Digital high impedance (electronically calibrated)
- Earth fault detection (electronically calibrated)
- Four configurable relay outputs
- One configurable contactor drive
- Four configurable isolated inputs
- Two voltage measurements
- Two temperature measurements
- One current measurement
- Two CANBUS ports
- LED status indicators

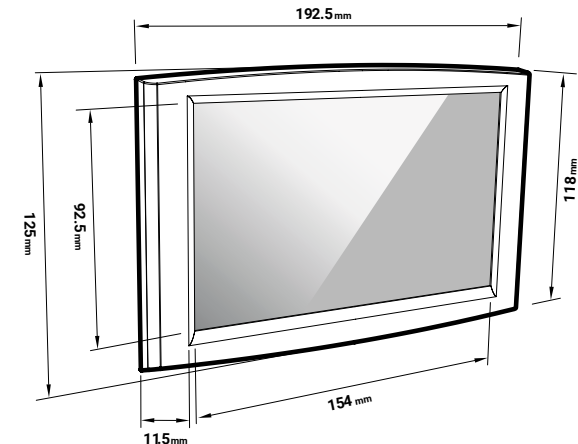

Contact us for a free system survey and learn more about our products.

[pe-systems.co.uk/technical](http://pe-systems.co.uk/technical)

Sales +44 (0)1942 260330

[sales@pe-systems.co.uk](mailto:sales@pe-systems.co.uk)



## SYSTEM CONTROLLER (FUNCTION)

The system controller serves as the control hub for the ACVF™ platform, offering a wide range of functions and capabilities, including:

- Configurable alarms (up to 32), including low voltage, high voltage, high voltage shutdown, mains fail, and more, with programmable delays and trigger sources
- Programmable inputs for boost start, BDT start, mains fail, contactor feedback, and more
- Programmable relay and contactor drive outputs for various alarms/indications
- Manual/automatic battery tests, including voltage and current settings, delays, lockouts, and time and/or Ah termination
- Manual/automatic boost functions with programmable voltage and current settings, delays, and lockouts
- Triggered boost function to initiate a boost operation after a specific time interval following an alarm, such as boosting an hour after an LV alarm clears
- Periodic refresh cycle for automatic refresh at programmable time intervals, up to 2 years
- Configurable temperature compensation, with options for lowest/highest/average temperature, using up to 4 probes, local or remote
- Configurable battery current/load current settings, with inputs from any board in the system
- Sharing functionality for up to 16 rectifiers

## EXPANSION BOARD

The ACVF™ platform accommodates expansion boards, with up to 8 available in a system. These expansion boards share the same base PCB as the system controller. They can be configured for various purposes, including battery symmetry (2/3 channels), earth fault detection, voltage measurements, digital high-impedance measurements, relay outputs, contactor drives, isolated inputs, temperature measurements, and current measurements. Each expansion board includes two CANBUS ports and status indication LEDs.

## CALIBRATION/TEST SYSTEM

The ACVF™ boards have been meticulously designed to facilitate electronic test and calibration. A semi-automatic programming/test/calibration system has been developed to:

- Program the board's software
- Calibrate the board
- Assign a unique serial number to the board
- Store the data in a database
- Conduct a basic board test
- Generate a label with the software version, serial number, and date

## CONFIGURATION

The ACVF™ system is configured via a PE-designed computer program, which can be accessed through a direct connection or network. System designers can generate, save, load, and test configurations, with the ability to store and roll back changes as needed.

The ACVF™ platform represents a transformative leap in battery charger technology, streamlining operations, improving performance, and providing extensive configurability to meet the diverse needs of our valued customers.

## Electrical Input/Output

<b>Input Voltage</b>	110-230 <sub>VAC</sub> 1-Phase and 380-480 <sub>VAC</sub> 3-Phase 50/60Hz +10% Variation
<b>Output Voltage Range</b>	12 <sub>VDC</sub> to 154 <sub>VDC</sub>
<b>System Output Range</b>	0.5k <sub>VVA</sub> up to 120k <sub>VVA</sub>
<b>Voltage Regulation</b>	+/- 1% steady state up to +/- 0.5%
<b>Efficiency</b>	>80% depending on options fitted

## Digital Controller

<b>DSP Micro Controller technology Instrumentation</b>	Standard Controller c/w Temperature Comp. 7" full colour touchscreen LCD display
--	--

## Battery Compatibility

<b>Technology</b>	Planté Lead Acid, Valve Regulated Lead Acid and Nickel cadmium Stationary battery types.
-------------------	--

## Environmental

<b>Operating Temperature</b>	-20°C to +40°C
<b>Storage Temperature</b>	-40°C to +60°C
<b>Humidity</b>	>95% non-condensing
<b>De-rate</b>	1% per °C above 40°C
<b>Enclosure</b>	Sheet steel, epoxy powder coated > IP20

## Alarms/Indications

<b>Local</b>	Tri-colour led & detailed system status on LCD panel. (Red = ALARM, Yellow = WARNING, Green = SYSTEM OK).
<b>Remotes</b>	Programmable Volt-free C/O Relay Contacts

## Standards

<b>Low Voltage Directive</b>	LVD 2014/35/EU
<b>Electrical Emissions</b>	BS EN61000-6-4: 2007+A1: 2011
<b>Electrical Immunity</b>	BS EN61000-6-2: 2005
<b>Electronic Converter Systems</b>	BS EN 62477-1:2012+A12:2021
<b>Temperature</b>	BS EN 60068-2-1/60068-2-2/60068-2-78
<b>Vibration</b>	BS EN 60255-21-1
<b>Shock</b>	BS EN 60255-21-2
<b>Rough Handling</b>	BS EN 60068-2-31
<b>Lightning Impulse</b>	BS EN61180-1:1992

Contact us for a free system survey and learn more about our products.

[pe-systems.co.uk/technical](http://pe-systems.co.uk/technical)

Sales +44 (0)1942 260330

[sales@pe-systems.co.uk](mailto:sales@pe-systems.co.uk)



For all our QHES Accreditations, please visit the website.